

Original BMW Accessories. Installation Instructions.



M Performance Aerodynamics Package Retrofit Kit BMW 3 Series Saloon (F 30)

Retrofit kit number

A **primed** M Performance Aerodynamics package comprises five retrofit kit numbers, depending on the type of engine and exhaust system.

single-sided single-pipe	single-sided twin-pipe	twin-sided single-pipe	
51 19 2 291 417	51 19 2 291 418	51 19 2 291 414	Rear Aerodynamics package
	51 19 2 291 364		Front primed Aerodynamics package
	51 19 2 291 404		Primed right side sill Aerodynamics package
	51 19 2 291 407		Primed left side sill Aerodynamics package
	51 19 2 240 983		M Performance side sill film

Installation time

The installation time is **approx. 3.0 hours**. This may vary depending on the condition of the car and the equipment in it. The installation time shown does not include any time spent on programming/coding.

The calculation of the total costs for the programming time must be factored into the calculation of retrofitting costs (no invoicing via warranty).

Important information

 If the front M Performance Aerodynamics Package (front splitter) is installed, either the M Performance rear spoiler part number 2 293 329 or part number 2 240 832 will also need to be installed. ◀

These installation instructions are primarily designed for use within the BMW dealership organisation and by authorised BMW service companies.

In any event, the target group for these installation instructions is specialist personnel trained on BMW cars with the appropriate specialist knowledge.

All work must be completed using the latest BMW repair manuals, wiring diagrams, servicing manuals and work instructions, in a rational order, using the prescribed tools (special tools) and observing current health and safety regulations.

If you experience installation or function problems, restrict troubleshooting to approx. 0.5 hours for mechanical work and 1.0 hour for electrical work.

To avoid unnecessary extra work and/or costs, send an inquiry straight away to the technical parts support team via the Aftersales Assistance Portal (ASAP).

Quote the following information:

- Chassis number,
- retrofit kit part number,
- a detailed description of the problem,
- any work already carried out.

Do not archive the hard copy of these installation instructions since daily updates are provided via ASAP!

Pictograms



Denotes instructions that draw your attention to dangers.



Denotes instructions that draw your attention to special features.

- ◀ Denotes the end of the instruction or warning text.

Installation information

Some of the installation steps are shown only on the left-hand side of the car, proceed in the same way on the right-hand side of the car.

All affected components must be at room temperature when they are being installed.

All pictures show LHD cars; proceed accordingly on RHD cars.



The car may be driven after approx. 24 hours and may be taken through a car wash after 48 hours. ◀



If the front M Performance Aerodynamics Package (front splitter) is installed, either the M Performance rear spoiler part number 2 293 329 or part number 2 240 832 will also need to be installed. ◀

Painting instructions

Check that all the parts fit accurately on the car before painting them. Primed parts must be pre-treated accordingly before painting.

To ensure correct painting, the EBA must be provided to the painter.

The BMW painting instructions must be observed (see ISTA No. 99 00 ...).

Ordering instructions

For the installation of the Front M Performance Aerodynamics Package (front splitter), Betalink (part number 82 69 9 408 866) must also be ordered.

Recommended special tools

None

Table of contents

Section	Page
1 Front M Performance Aerodynamics package parts list	4
2 M Performance Aerodynamics package side sill parts list	5
3 Rear M Performance Aerodynamics package parts list	6
4 Preparatory work	7
5 Installing the front M Performance Aerodynamics package	8
6 Installing the M Performance side sill films	14
7 Installing the M Performance Aerodynamics package side sills	15
8 Installing the rear M Performance Aerodynamics package	18
9 Concluding work and coding	19

1. Front M Performance Aerodynamics package parts list

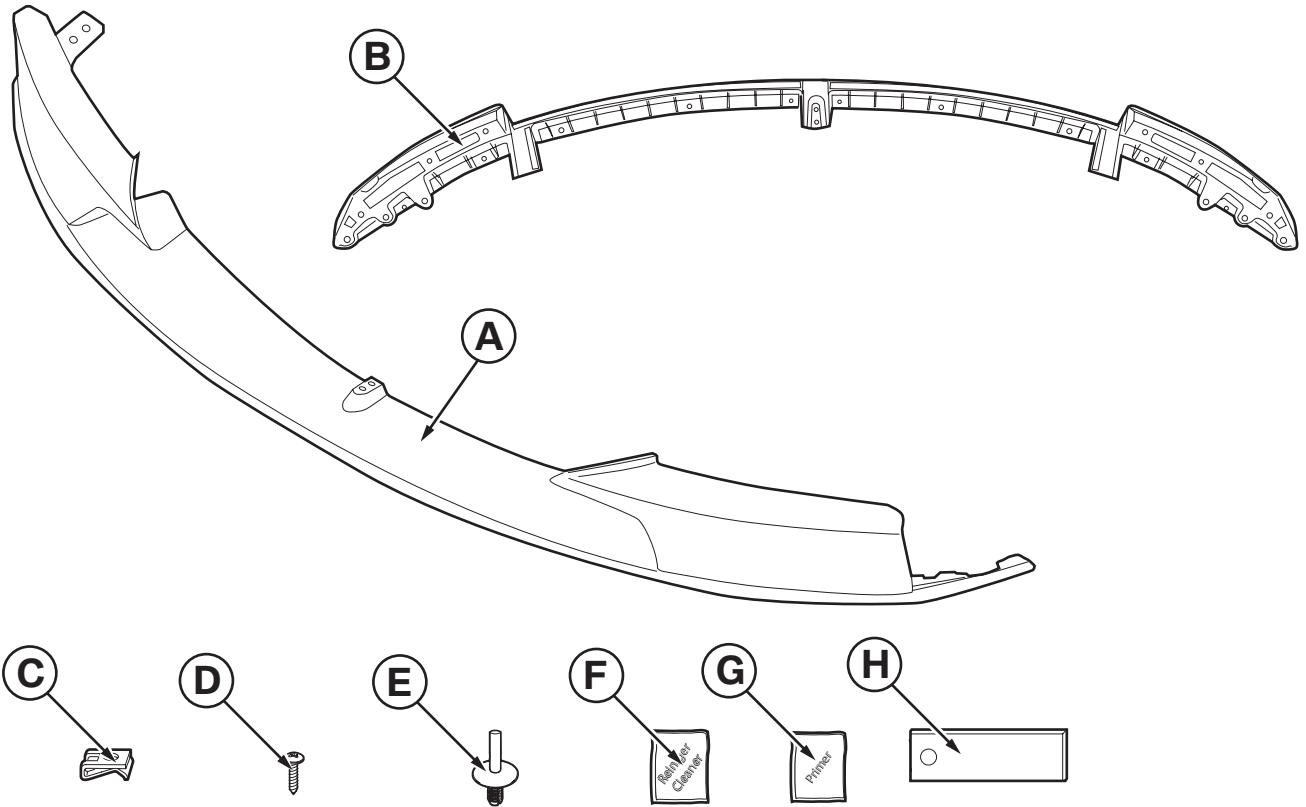

F30 0122 V

Legend

- A** Front splitter
- B** Adapter
- C** C clip, 4.8 mm (2 x), part number 6 951 655
- D** Torx screw, 4.8 x 32 mm (2 x), part number 9 112 637
- E** Blind rivet, 5.0 x 10.0 mm (22 x), part number 7 002 953
- F** Cleaning pad
- G** Primer pad
- H** Installation plate

2. M Performance Aerodynamics package side sill parts list

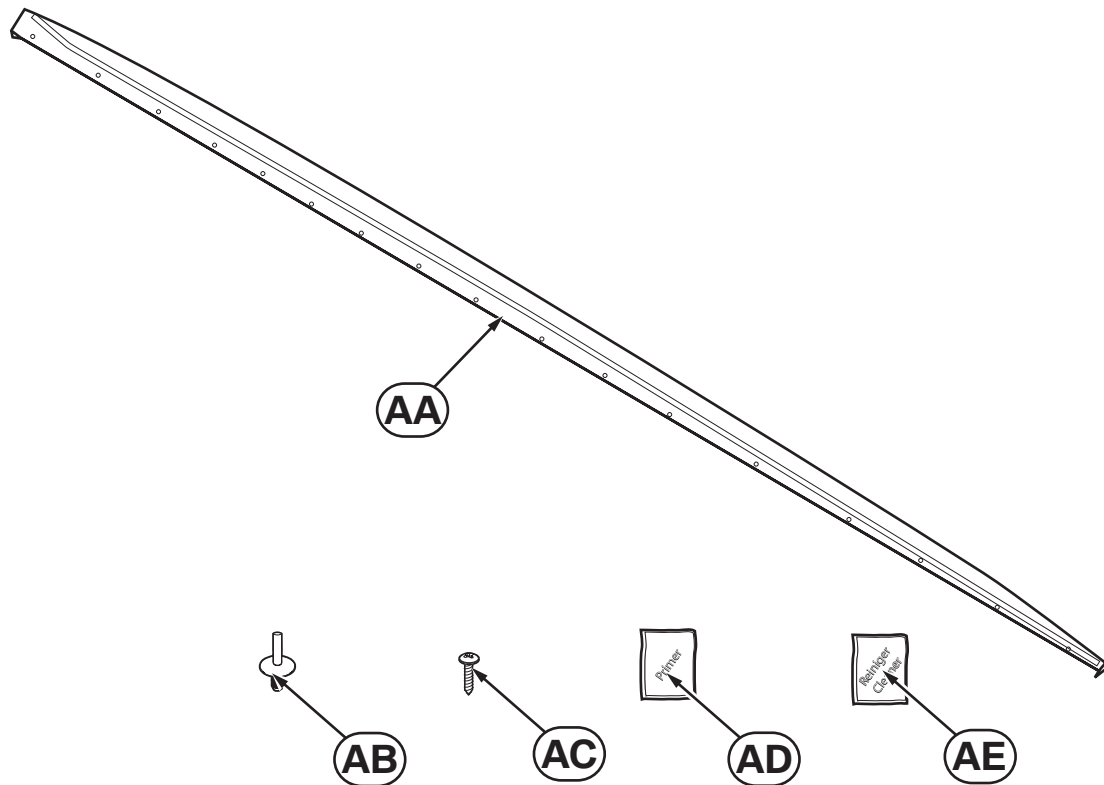

F30 0123 V

Legend

- AA** Left side sill attachment section (right not shown)
- AB** Blind rivet, 5.0 x 8.0 mm (17 x per side sill package), part number 7 002 953
- AC** Oval-headed screw, 4.2 x 14 mm (11 x per side sill package), part number 7 133 553
- AD** Primer pad
- AE** Cleaning cloth

3. Rear M Performance Aerodynamics package parts list

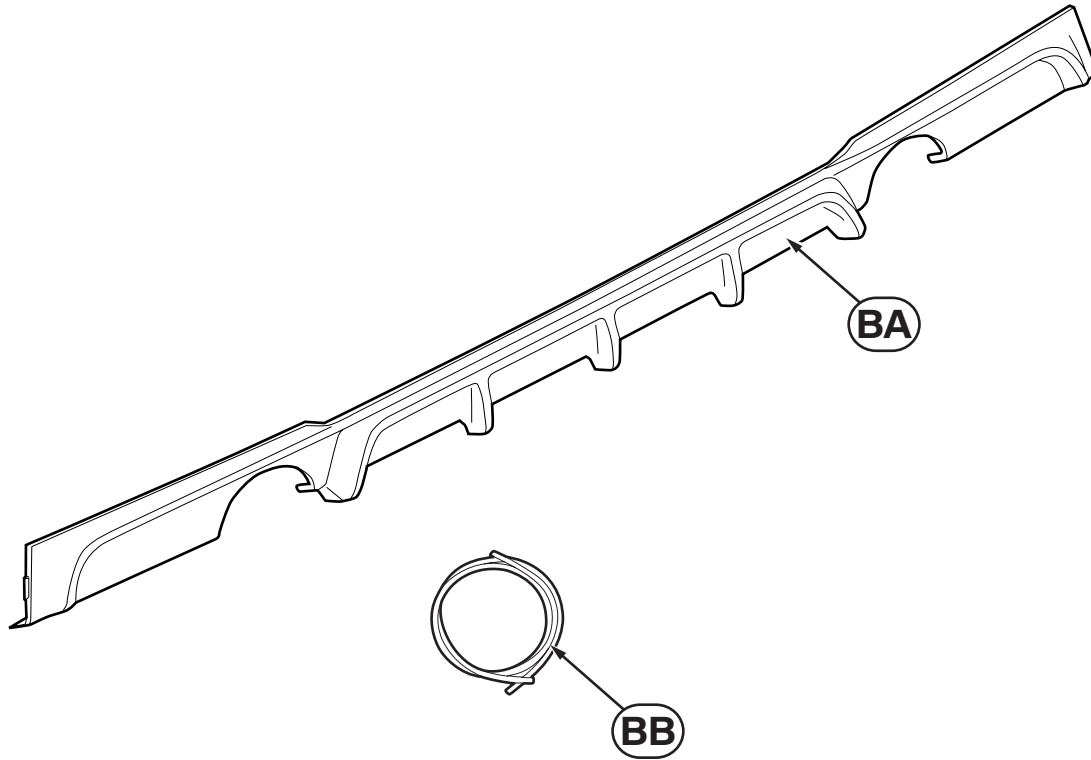

F30 0124 V

Legend

- BA** Bottom rear bumper trim (illustration shows double-sided and single-pipe exhaust system version)
- BB** Masking tape

4. Preparatory work

The following components must be removed first of all

Lower rear bumper trim (keep the screws and rivets, they will be required again for later installation)

ISTA No.

51 12 ...

5. Installing the front M Performance Aerodynamics package

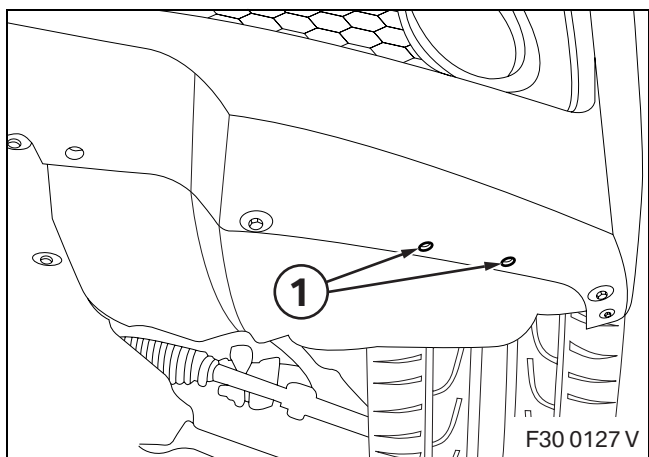

Remove the rivets (1) on the left and right-hand side.

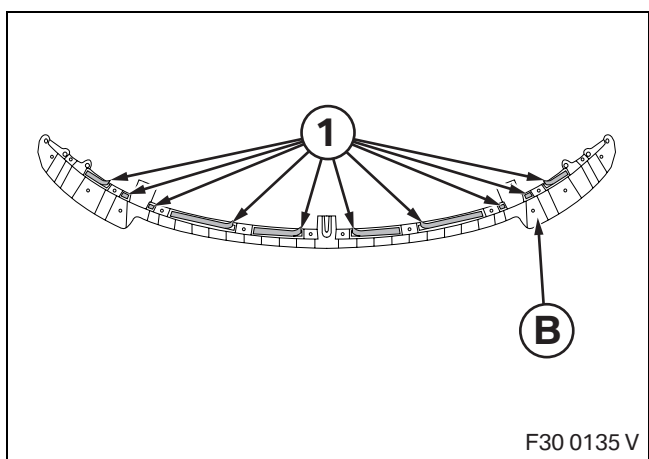

On the front of adapter **B**, fold the protective film (1) on the adhesive strips outwards at the ends.

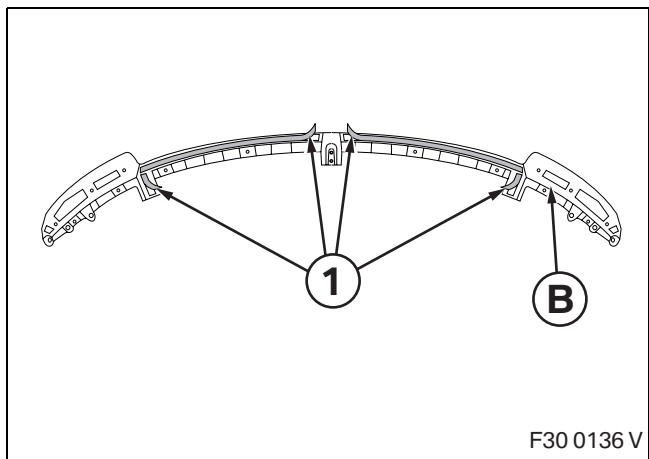

On the back of adapter **B**, fold the protective film (1) on the adhesive strips outwards at the ends.

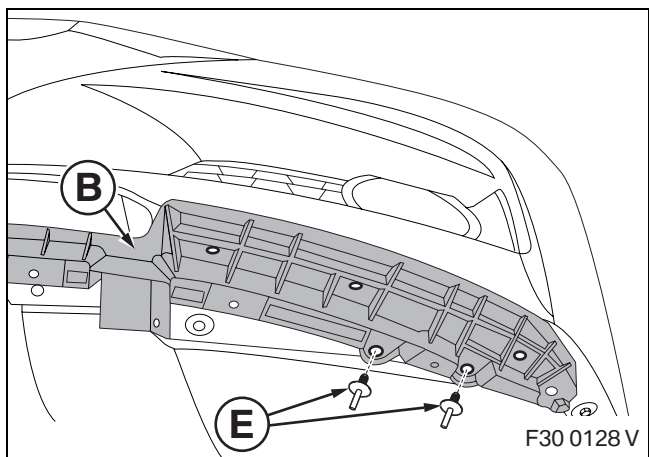

Secure adapter **B** using blind rivets **E**.

▶ Then carry out the same step on the right-hand side. ◀

5. Installing the front M Performance Aerodynamics package

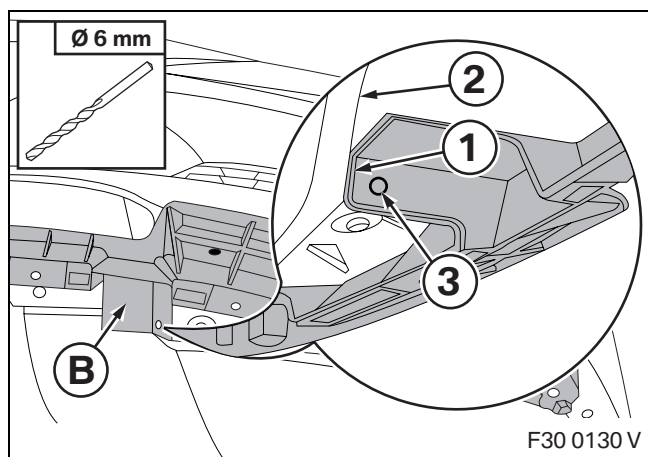

▶ When drilling, note the maximum drilling depth. ◀

Press adapter **B** upwards onto the front apron. Then hold the edge (1) of adapter **B** flush with the edge (2) of the front apron and drill a hole (3) using a **6 mm diameter** drill bit.

▶ Then carry out the same step on the right-hand side. ◀

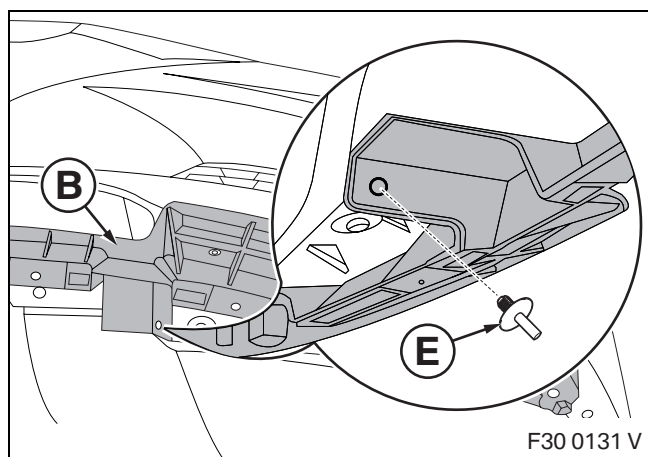

Secure adapter **B** using blind rivet **E**.

▶ Then carry out the same step on the right-hand side. ◀

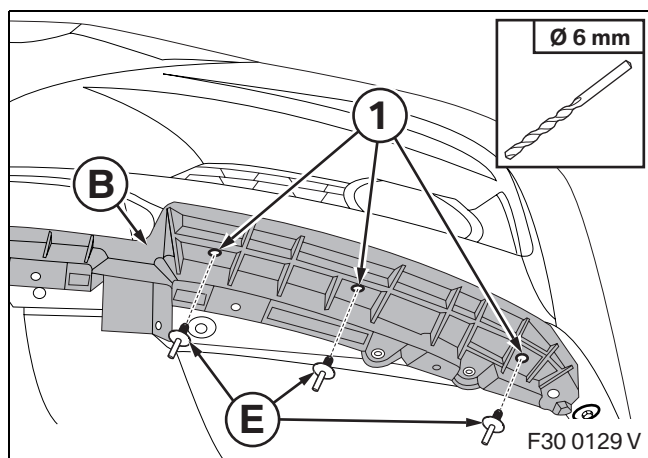

▶ When drilling, note the maximum drilling depth. ◀

Drill through the front apron at the drill holes (1) using a **6 mm diameter** drill bit.

Then secure adapter **B** using blind rivets **E**.

▶ Then carry out the same step on the right-hand side. ◀

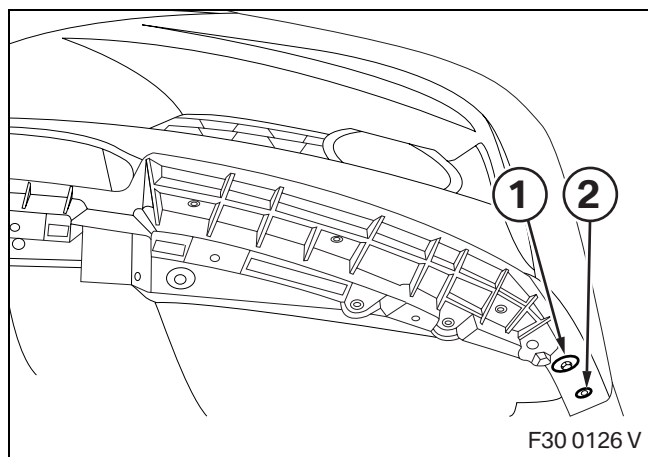

Remove the screw (1) and rivet (2).

▶ Then carry out the same step on the right-hand side. ◀

5. Installing the front M Performance Aerodynamics package

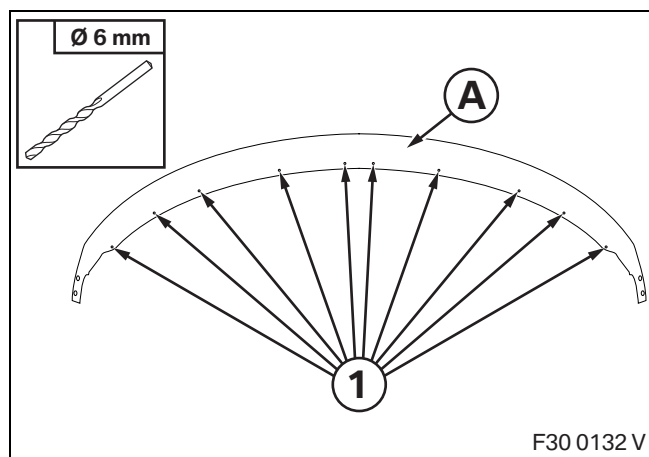

Drill front splitter **A** at the ten pre-illustrated drill hole points (1) using a **6 mm diameter** drill bit.

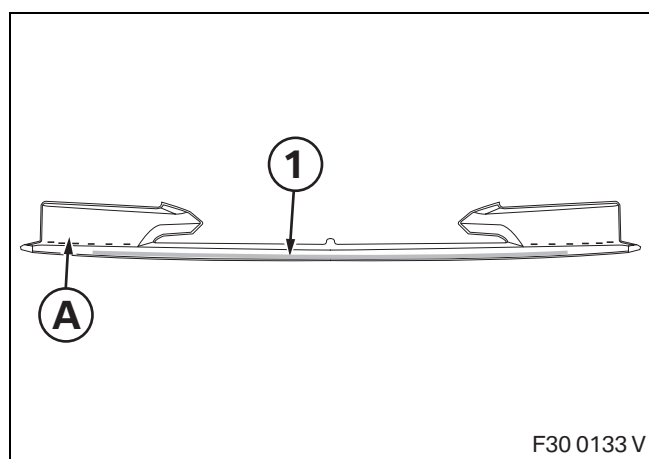

Only prime the bonding surfaces that come into contact with the adhesive strip of adapter **B**. ◀

Prime the inside of front splitter **A** at the points indicated (1).

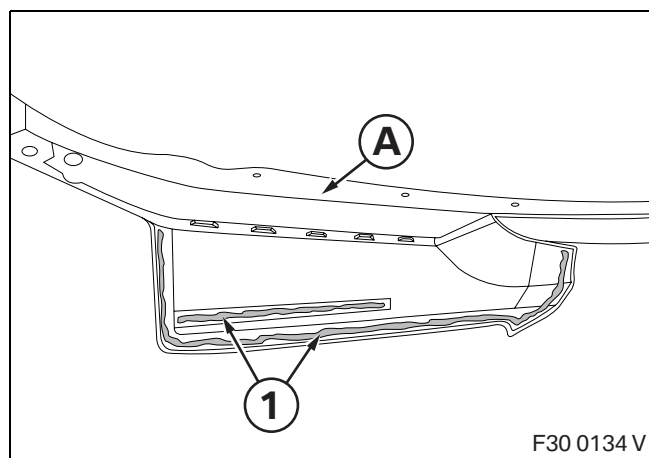

Apply Betalink (1) at the points indicated on the inside of front splitter **A**.

Then carry out the same step on the right-hand side. ◀

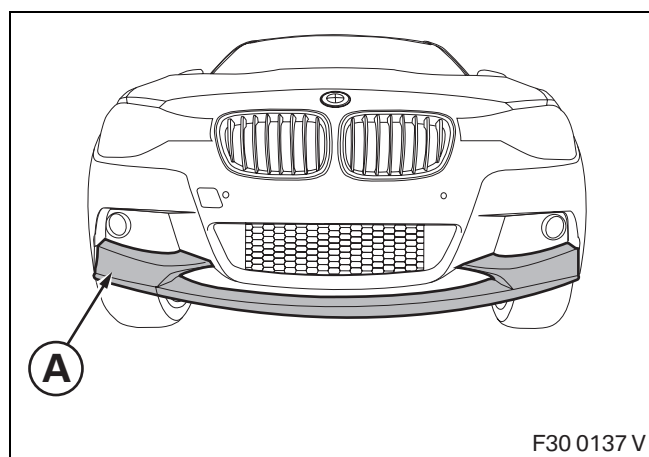

The bonding surfaces must be completely clean, dry and free from grease.

Front splitter **A** must audibly engage. ◀

Place front splitter **A** on the front apron of the car, align it, press it into place and allow it to engage.

5. Installing the front M Performance Aerodynamics package

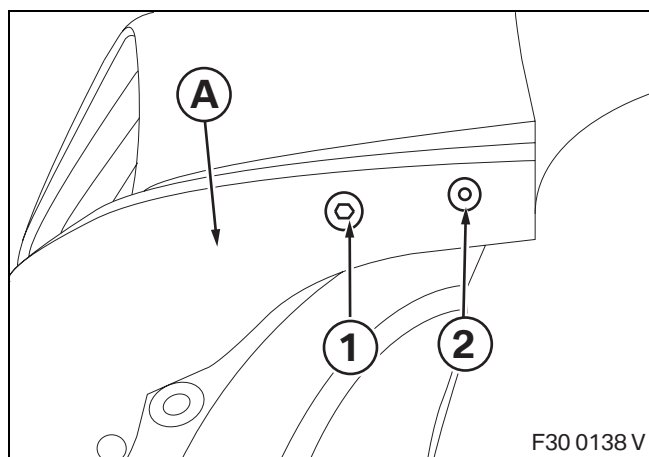

Tighten or insert the existing screw (1) and rivet (2) on the outer side of front splitter **A**.

▶ Then carry out the same step on the right-hand side. ◀

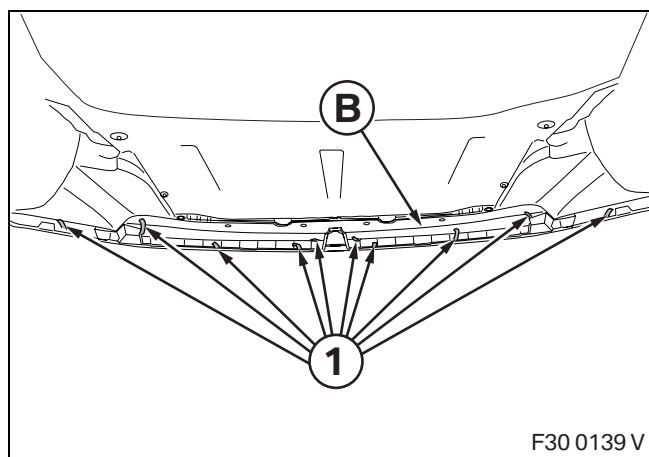

Remove the protective films (1) from adapter **B**.

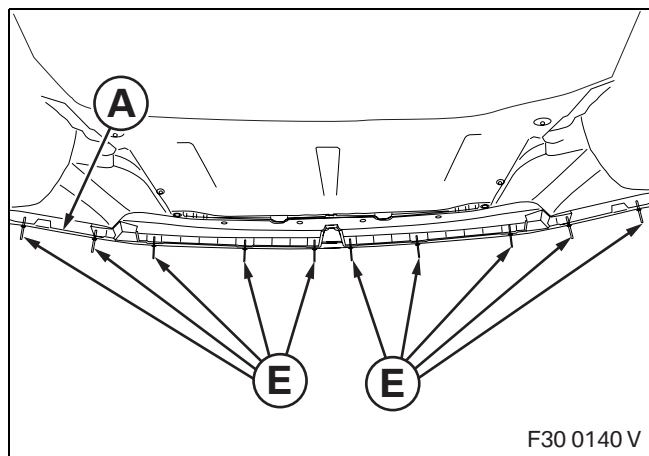

Secure front splitter **A** from underneath using ten blind rivets **E**.

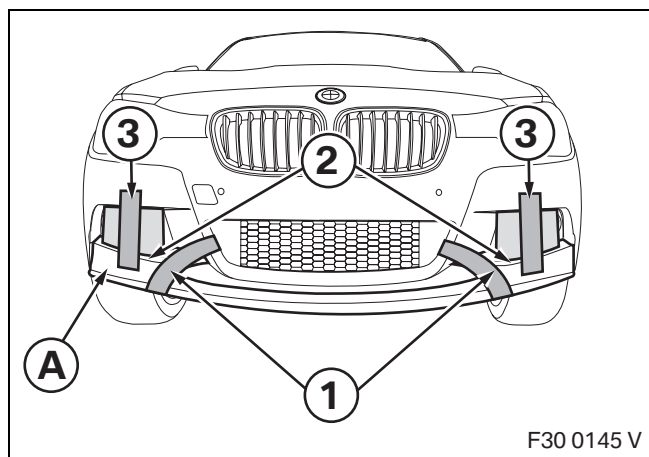

Secure front splitter **A** using suitable adhesive strips (1) to the front apron.

A large surface area of pressure must then be generated on the internal surfaces (2) of front splitter **A** using suitable means. These means must be secured in place using suitable adhesive strips (3).

▶ Remove any Betalink that oozes out immediately. Fill any tolerance adjustment gaps with Betalink. ◀

Allow front splitter **A** to remain in this position for 2 hours. Then release the adhesive strips.

5. Installing the front M Performance Aerodynamics package

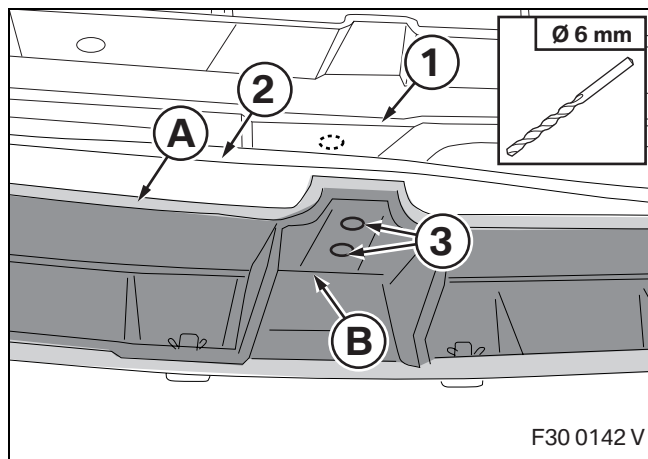

⏏ When drilling, note the maximum drilling depth. The level (1) must also be drilled through. ◀

Press front splitter **A** upwards, aligning the contours of front apron (2) and front splitter **A** with each other as you do so.

Then drill two holes (3) with a **6 mm diameter** drill bit from underneath through front splitter **A** to through the level (1).

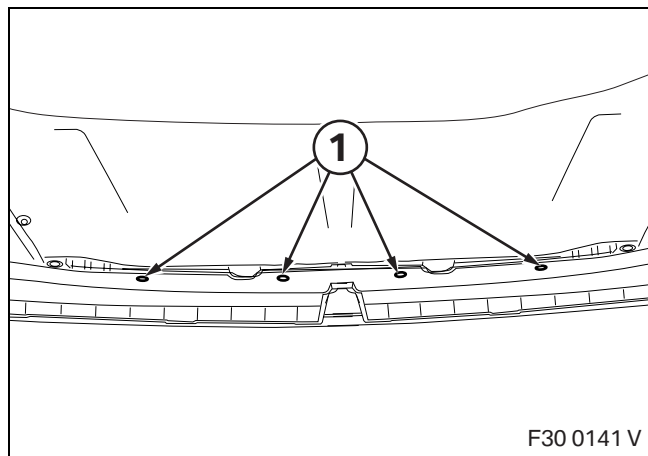

Remove the four expanding rivets (1).

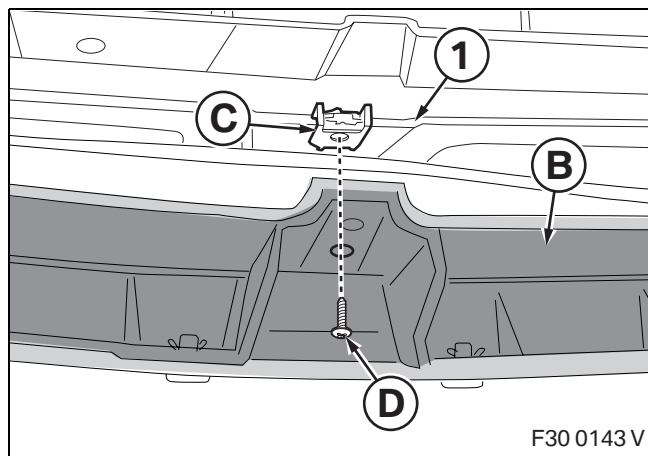

Position C clip **C** on the edge of the level (1). Screw Torx screw **D** through adapter **B** into C-clip **C**.

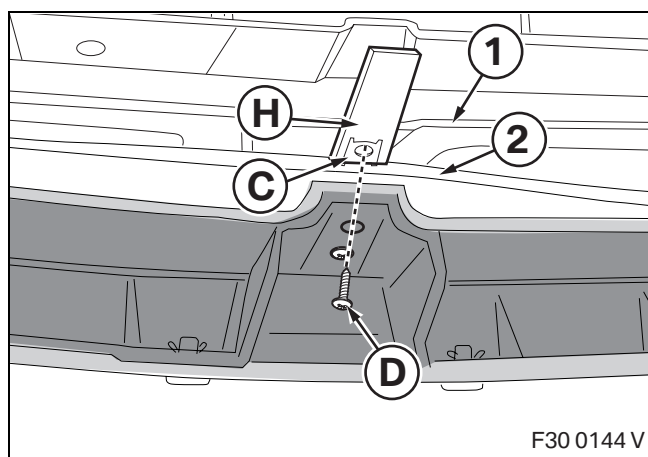

Slide C-clip **C** onto installation plate **H**.

Insert installation plate **H** between level (1) and front apron (2) with the sheet metal nut first, align C-clip **C** on the second drill hole and screw in Torx screw **D**.

Then tighten both Torx screws **D**.

5. Installing the front M Performance Aerodynamics package

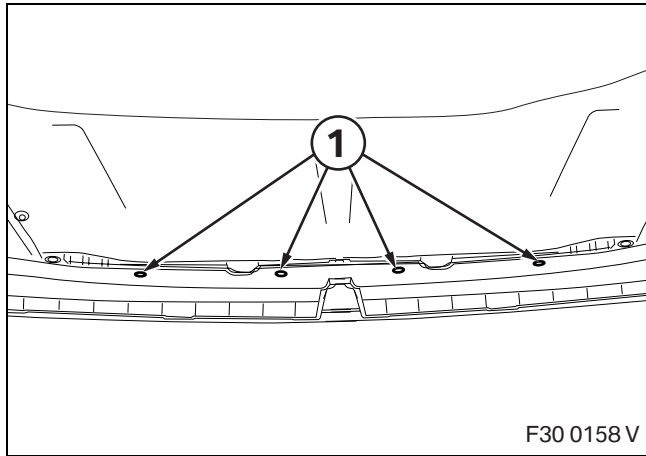

Reinsert the four expanding rivets (1).

6. Installing the M Performance side sill films

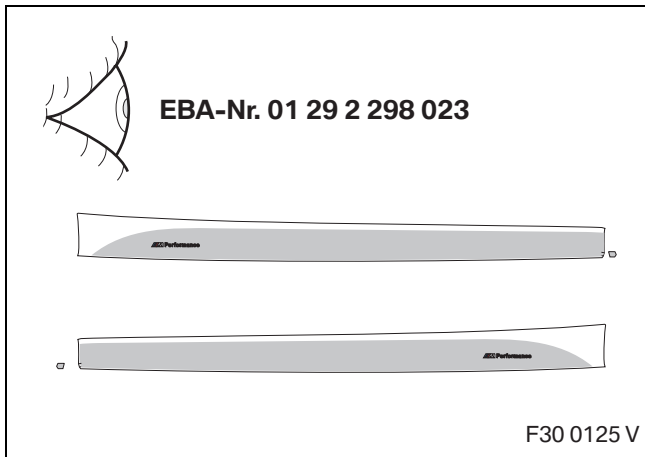

▶ Before installing the M Performance Aerodynamics package side sill, the M Performance side sill films must be installed in accordance with the installation instructions with part number 01 29 2 298 023. ◀

7. Installing the M Performance Aerodynamics package side sills

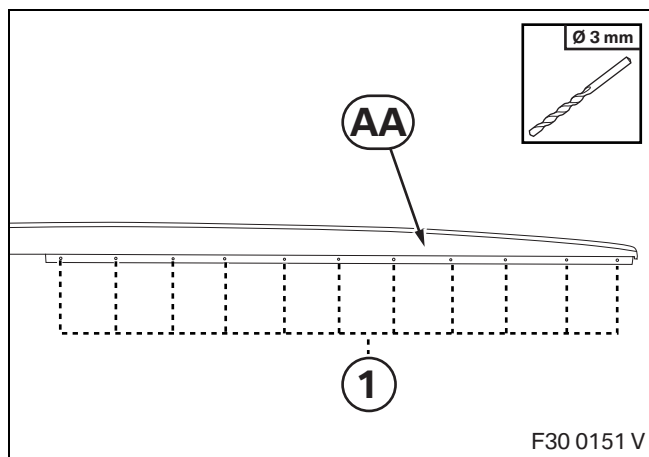

Carefully drill the narrow surface of the side sill at the 11 drill holes (1) on left side sill attachment section **AA** using a **3 mm diameter** drill bit.

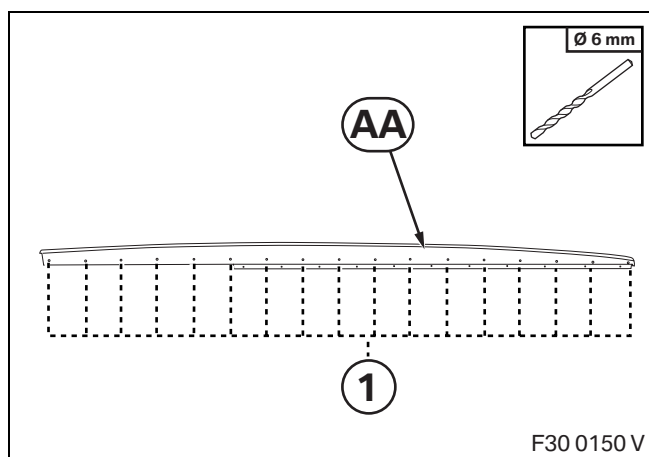

Carefully drill the side sill at the 17 drill holes (1) on left side sill attachment section **AA** using a **6 mm diameter** drill bit.

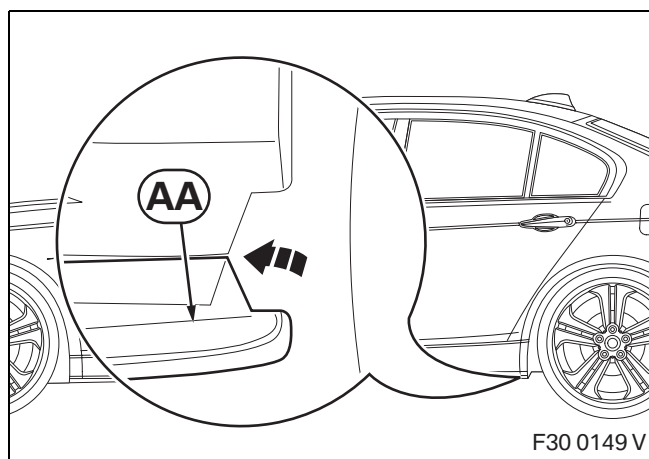

▶ The bonding surfaces must be completely clean, dry and free from grease. ◀

Hook left side sill attachment section **AA** at the rear on the side sill, push it inwards and forwards and align it.

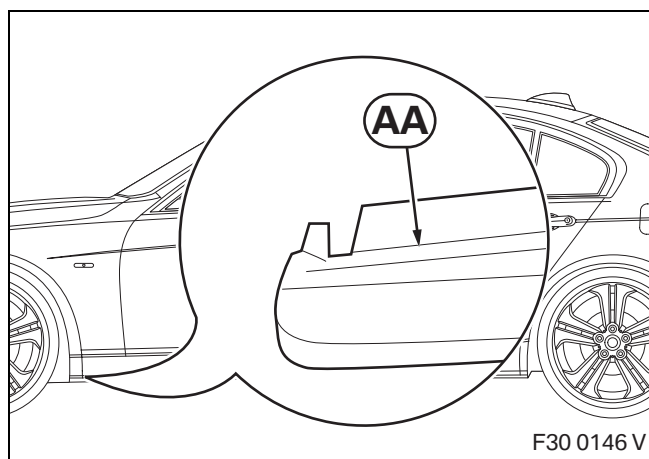

Secure left side sill attachment section **AA** on the front to the side sill.

7. Installing the M Performance Aerodynamics package side sills

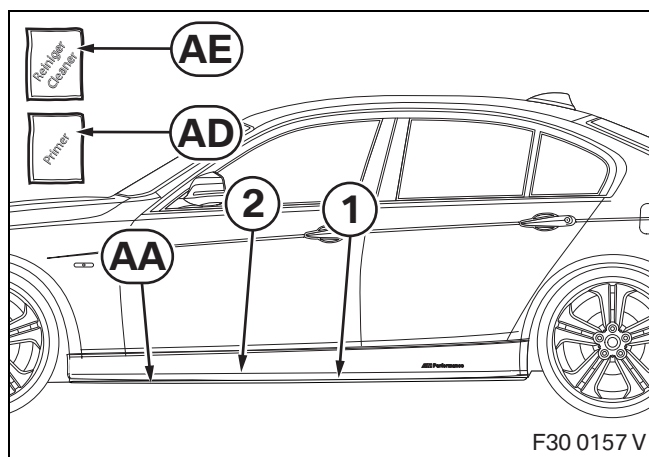

Press left side sill attachment section **AA** upwards and using a suitable tool draw a line (1) at the upper edge of left side sill attachment section **AA** on the side sill.

Stick on masking tape (2) above and along the drawn-on line (1).

Remove left side sill attachment section **AA**.

Clean the bonding surface below the masking tape (2) with cleaner **AE** and prime with primer pad **AD**.

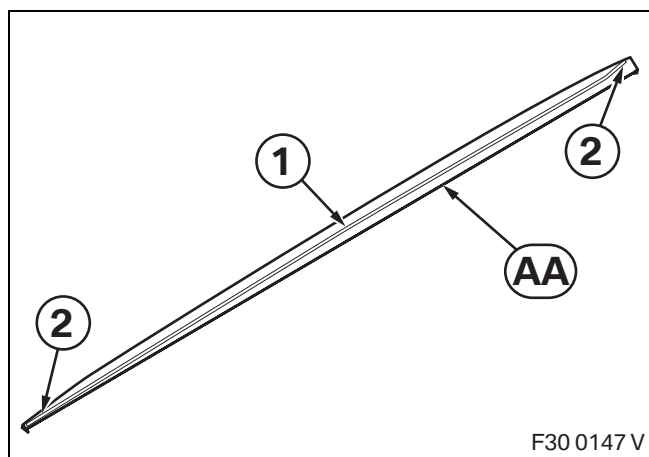

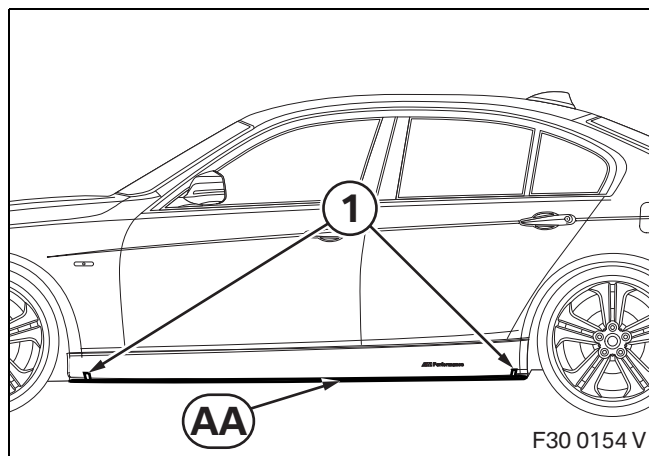

Remove the backing film of the adhesive strip (1) at the ends (2) of left side sill attachment section **AA** and fold outwards at an angle of 90°.

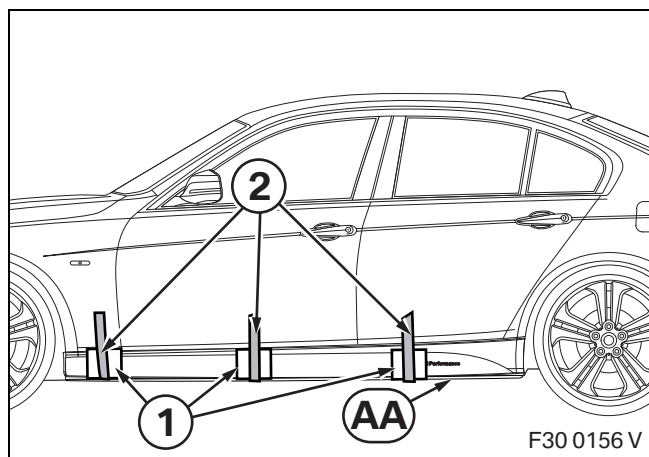

Allow left side sill attachment section **AA** to engage in the rear side sill and align it forwards.

Remove the backing film (1) from the adhesive strip and press on left side sill attachment section **AA**.



 In order to avoid damage caused by adhesive surfaces, the M Performance side sill film must be protected with suitable materials (1). ◀

Secure left side sill attachment section **AA** as shown using suitable adhesive strips (2).

7. Installing the M Performance Aerodynamics package side sills

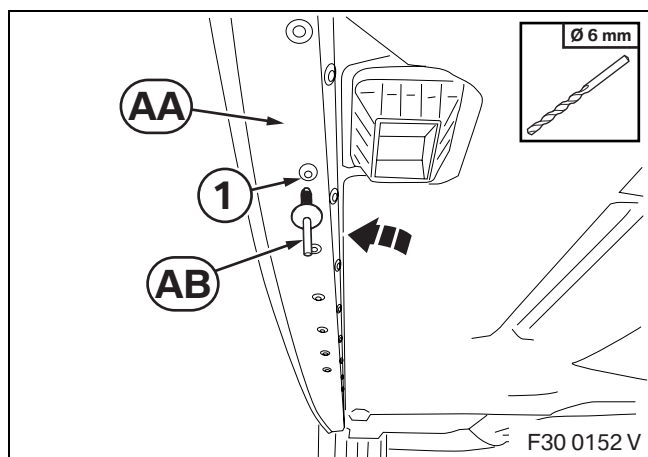

▶ When drilling, note the maximum drilling depth. ◀

Using the pre-drilled holes (1) in left side sill attachment section **AA**, drill through the side sill with a **6 mm diameter** drill bit.

Insert blind rivets **AB** and secure.

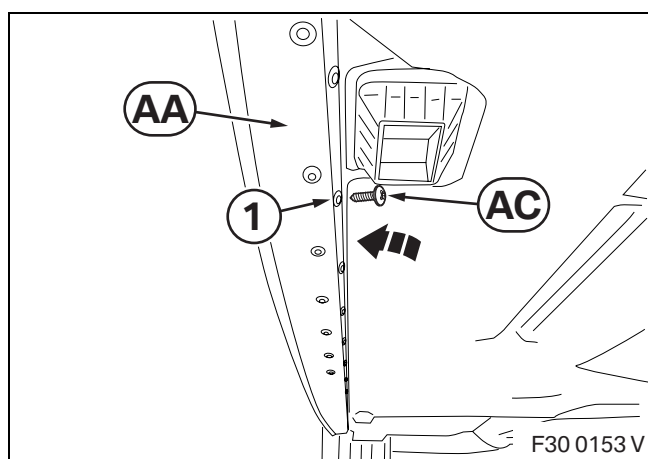

Screw oval-headed screws **AC** into the pre-drilled holes (1) on left side sill attachment section **AA**.

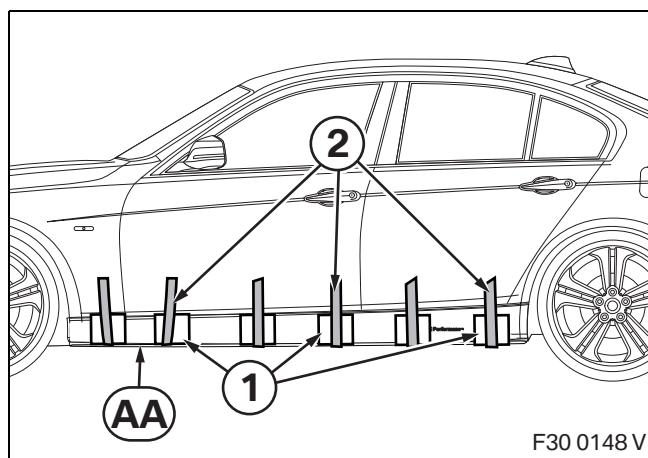

▶ In order to avoid damage caused by adhesive surfaces, the M Performance side sill film must be protected with suitable materials (1). ◀

Secure left side sill attachment section **AA** as shown using further adhesive strips (2).

After around 30 minutes, carefully remove the adhesive strip (2) from left side sill attachment section **AA** from the bottom to the top.

8. Installing the rear M Performance Aerodynamics package

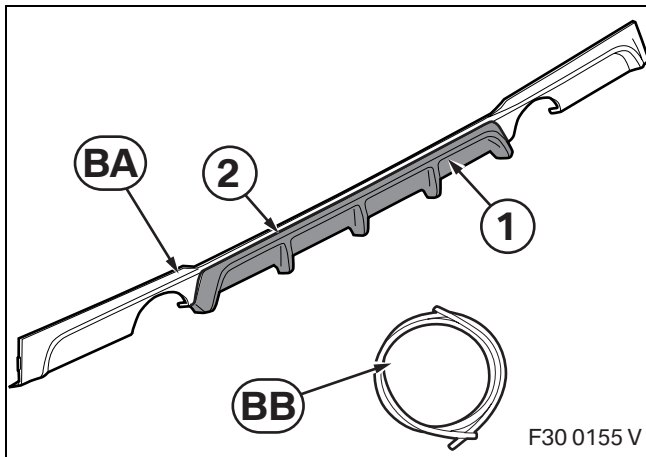

▶ Paint the unmasked areas in the colour of the car. ◀

Before painting, mask the marked areas (1) of bottom rear bumper trim **BA** using masking tape and masking tape **BB** and using the joint (2) provided.

Fit bottom rear bumper trim **BA** as per ISTA No. 51 12

9. Concluding work and coding

The retrofit system does not require coding.

- Conduct a brief test
- Conduct a function test
- Re-assemble the car in a logical manner